

SMD Power Inductor

CDRH12D78E/LD



Recommended Type

Description

- Magnetically shielded
- LxWxH:12.5x12.8x8.0mm Max.
- Product weight: 3.9 g (Ref.)
- Moisture Sensitivity Level: 1



Environmental Data

- Operating temperature range: -40°C~+105°C (including coil's self temperature rise)
- Storage temperature range: -40°C~+105°C

Packaging

- Carrier tape and reel packaging
- 500pcs per reel

Applications

- DC/DC converter such as Buck/Boost, SEPIC and Zeta for any non-automotive application

Dimension - [mm]

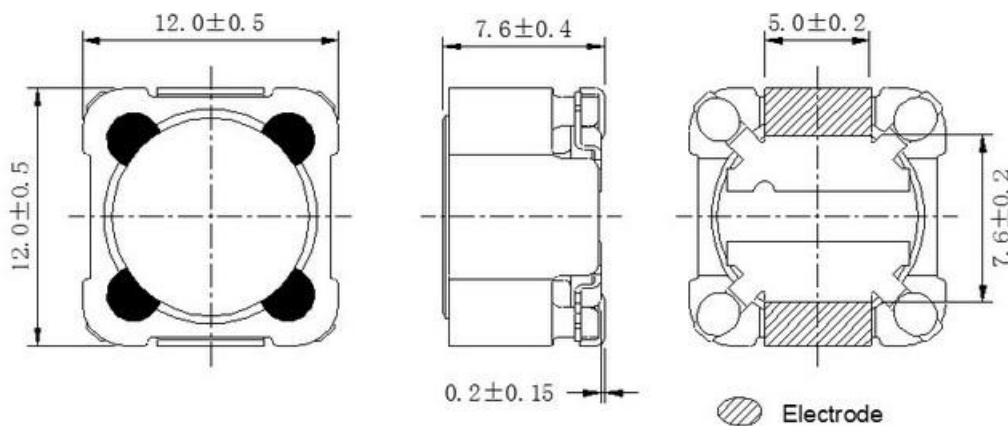

Recommended Land pattern - [mm]

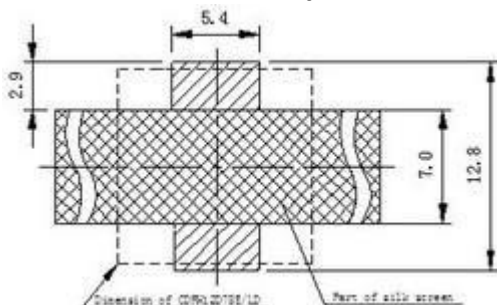

Wire Connection

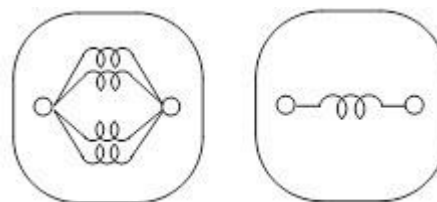

SMD Power Inductor

CDRH12D78E/LD

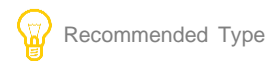

Electrical Characteristics

Part Number	Inductance [Within] (μ H) ※1	D.C.R. at 20°C Max.(Typ.) (m Ω)	Saturation Current (A) Max.(Typ.) ※2	Temperature Rise Current (A) Max.(Typ.) ※3
CDRH12D78ELDNP-1R0NC	1.00 \pm 30%	6.50 (5.00)	20.00 (25.00)	(14.20)
CDRH12D78ELDNP-1R8NC	1.80 \pm 30%	8.20 (6.30)	15.70 (19.70)	(12.80)
CDRH12D78ELDNP-2R4NC	2.40 \pm 30%	10.50 (8.10)	14.20 (17.70)	(11.50)
CDRH12D78ELDNP-3R5NC	3.50 \pm 30%	12.40 (9.50)	11.80 (14.70)	(10.30)
CDRH12D78ELDNP-5R8NC	5.80 \pm 30%	16.20 (12.40)	9.00 (11.20)	(9.60)
CDRH12D78ELDNP-7R4NC	7.40 \pm 30%	17.70 (13.60)	8.40 (10.50)	(8.70)
CDRH12D78ELDNP-100MC	10.00 \pm 20%	19.50 (15.00)	6.70 (8.40)	(7.80)
CDRH12D78ELDNP-120MC	12.00 \pm 20%	21.30 (16.40)	6.45 (7.50)	(7.40)
CDRH12D78ELDNP-150MC	15.00 \pm 20%	28.60 (22.00)	6.00 (7.10)	(6.80)
CDRH12D78ELDNP-180MC	18.00 \pm 20%	31.20 (24.00)	5.10 (6.40)	(6.50)
CDRH12D78ELDNP-220MC	22.00 \pm 20%	36.40 (28.00)	4.70 (5.80)	(6.30)
CDRH12D78ELDNP-270MC	27.00 \pm 20%	41.60 (32.00)	4.20 (5.40)	(5.70)
CDRH12D78ELDNP-330MC	33.00 \pm 20%	57.00 (43.80)	3.75 (4.70)	(5.00)
CDRH12D78ELDNP-470MC	47.00 \pm 20%	78.00 (60.00)	3.25 (4.10)	(4.10)
CDRH12D78ELDNP-680MC	68.00 \pm 20%	120 (93.00)	2.65 (3.30)	(3.20)
CDRH12D78ELDNP-101MC	100 \pm 20%	151 (119)	2.10 (2.70)	(2.60)
CDRH12D78ELDNP-151MC	150 \pm 20%	235 (188)	1.76 (2.20)	(2.10)
CDRH12D78ELDNP-181MC	180 \pm 20%	288 (231)	1.60 (2.00)	(1.90)
CDRH12D78ELDNP-221MC	220 \pm 20%	357 (286)	1.40 (1.80)	(1.55)
CDRH12D78ELDNP-331MC	330 \pm 20%	518 (415)	1.20 (1.50)	(1.45)
CDRH12D78ELDNP-471MC	470 \pm 20%	718 (575)	1.00 (1.28)	(1.23)
CDRH12D78ELDNP-681MC	680 \pm 20%	1030 (824)	0.85 (1.07)	(1.05)
CDRH12D78ELDNP-102MC	1000 \pm 20%	1500 (1270)	0.70 (0.86)	(0.82)

Note: This specification is subject to change without notice. Please contact your nearest sales office for updated information when placing an order.

SMD Power Inductor

CDRH12D78E/LD



※1 Measuring frequency: $1.0\ \mu\text{H} \sim 7.4\ \mu\text{H}$ at 100kHz $10\ \mu\text{H} \sim 1.0\text{mH}$ at 1kHz

※2 Saturation current: This indicates the value of D.C. current when the inductance becomes 25% lower than its initial value. ($T_a=25^\circ\text{C}$)

※3 Temperature rise current: The (actual) value of D.C. current when the temperature of coil becomes $\Delta T=40^\circ\text{C}$ ($T_a=20^\circ\text{C}$).

Solder Reflow Condition

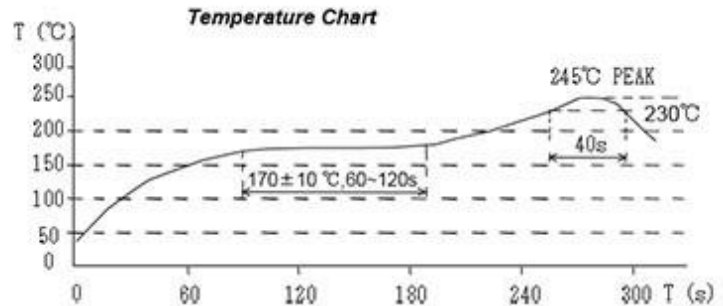
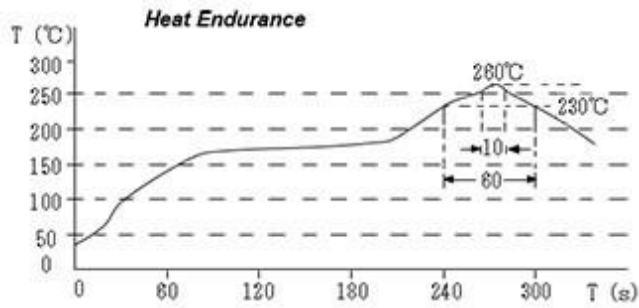

SMD Power Inductor

CDRH12D78E/LD



Saturation Current & Temperature Rise Graph

— L (20°C) — ΔT

1. CDRH12D78ELDNP-1R0NC



DC(A)

2. CDRH12D78ELDNP-1R8NC

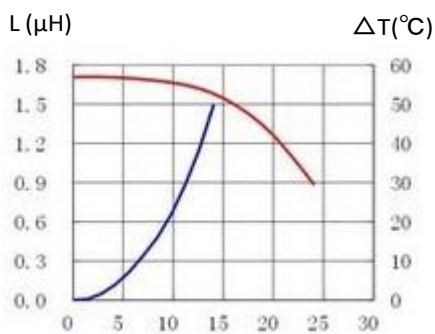

DC(A)

3. CDRH12D78ELDNP-2R4NC

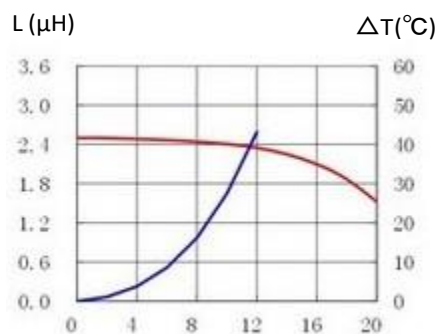

DC(A)

4. CDRH12D78ELDNP-3R5NC

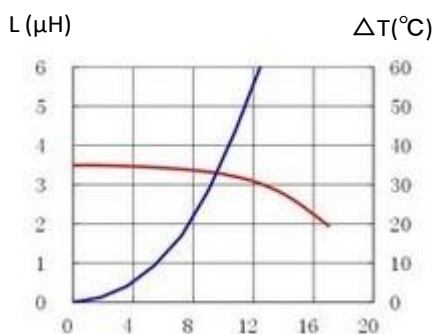

DC(A)

5. CDRH12D78ELDNP-5R8NC

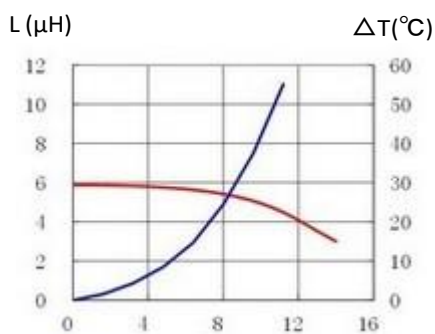

DC(A)

6. CDRH12D78ELDNP-7R4NC

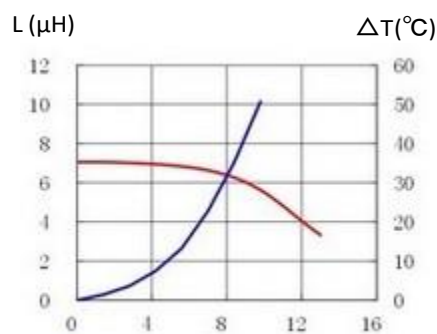

DC(A)

7. CDRH12D78ELDNP-100MC

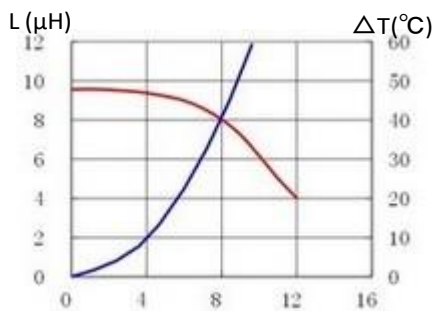

DC(A)

8. CDRH12D78ELDNP-120MC

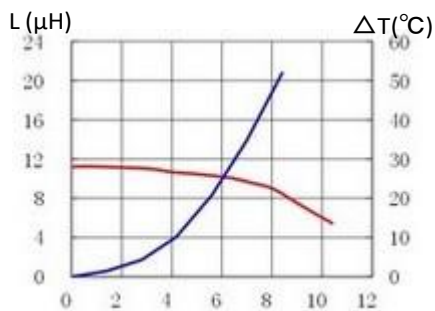

DC(A)

9. CDRH12D78ELDNP-150MC

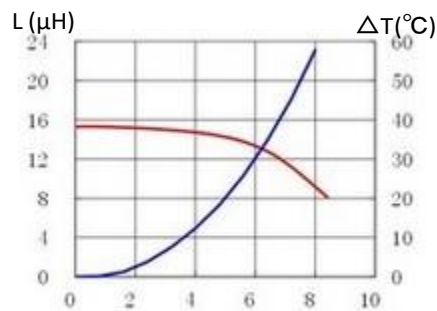

DC(A)

Note: This specification is subject to change without notice. Please contact your nearest sales office for updated information when placing an order.

SMD Power Inductor

CDRH12D78E/LD



Recommended Type

10. CDRH12D78ELDNP-180MC

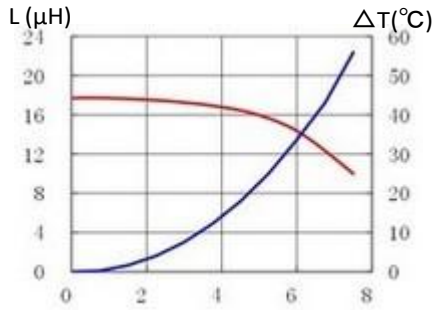

DC(A)

11. CDRH12D78ELDNP-220MC

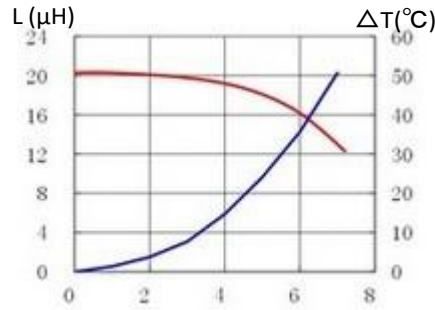

DC(A)

12. CDRH12D78ELDNP-270MC

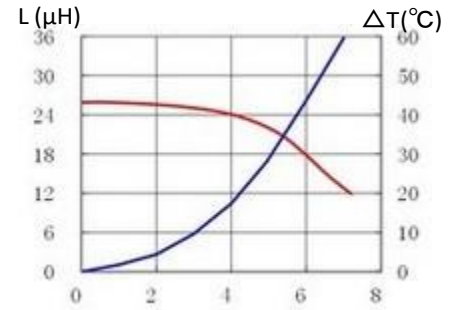

DC(A)

13. CDRH12D78ELDNP-330MC

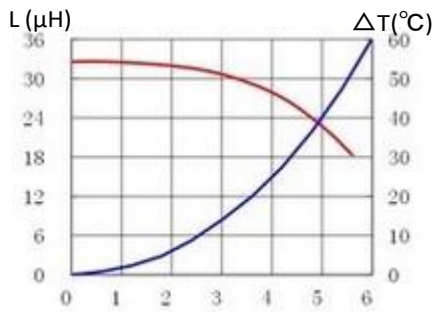

DC(A)

14. CDRH12D78ELDNP-470MC

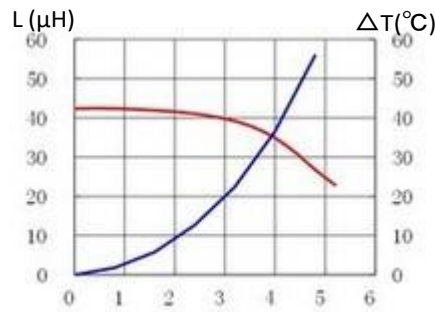

DC(A)

15. CDRH12D78ELDNP-680MC

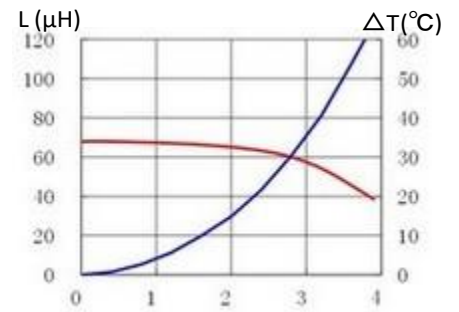

DC(A)

16. CDRH12D78ELDNP-101MC

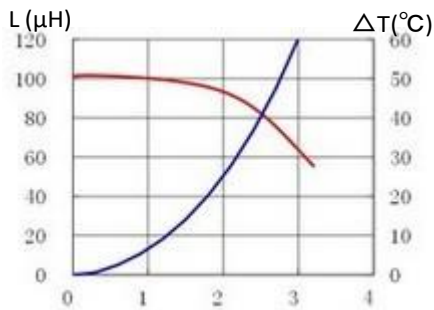

DC(A)

17. CDRH12D78ELDNP-151MC

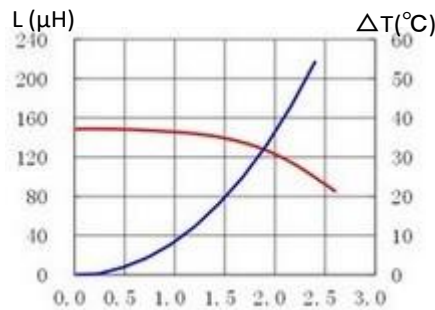

DC(A)

18. CDRH12D78ELDNP-181MC

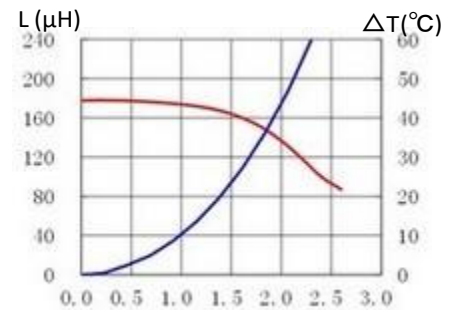

DC(A)

SMD Power Inductor

CDRH12D78E/LD



Recommended Type

19. CDRH12D78ELDNP-221MC

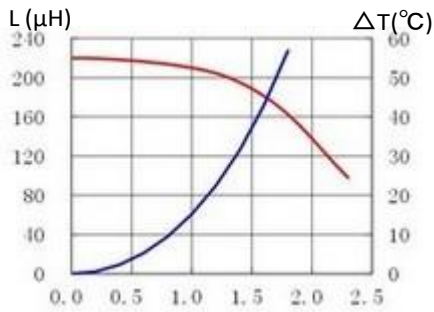

DC(A)

20. CDRH12D78ELDNP-331MC

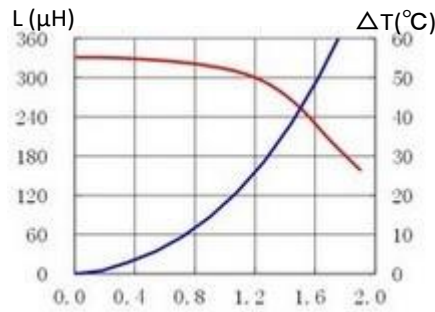

DC(A)

21. CDRH12D78ELDNP-471MC

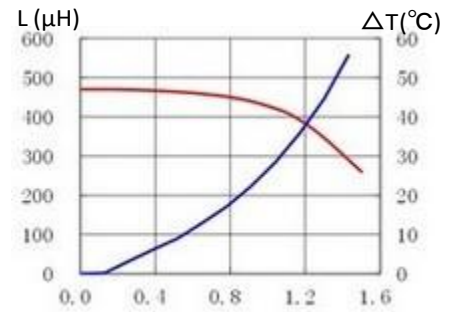

DC(A)

22. CDRH12D78ELDNP-681MC

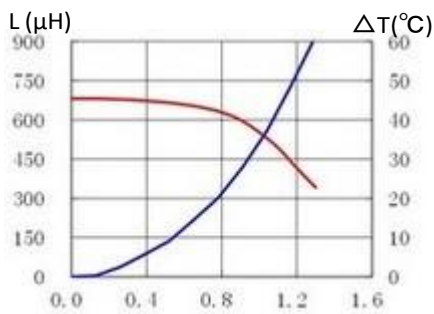

DC(A)

23. CDRH12D78ELDNP-102MC

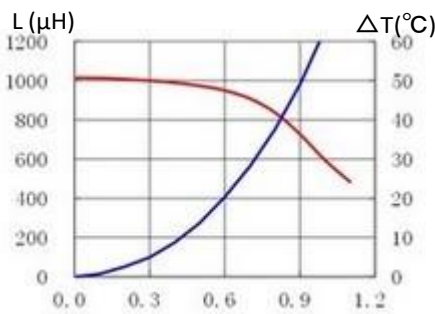

DC(A)



For sales office information, please [click here](#) to visit our website.